

RDW1 Rim drive winding machine

Max drum weight	2 tonne
Max drum size	1600 mm dia 1200 mm wide

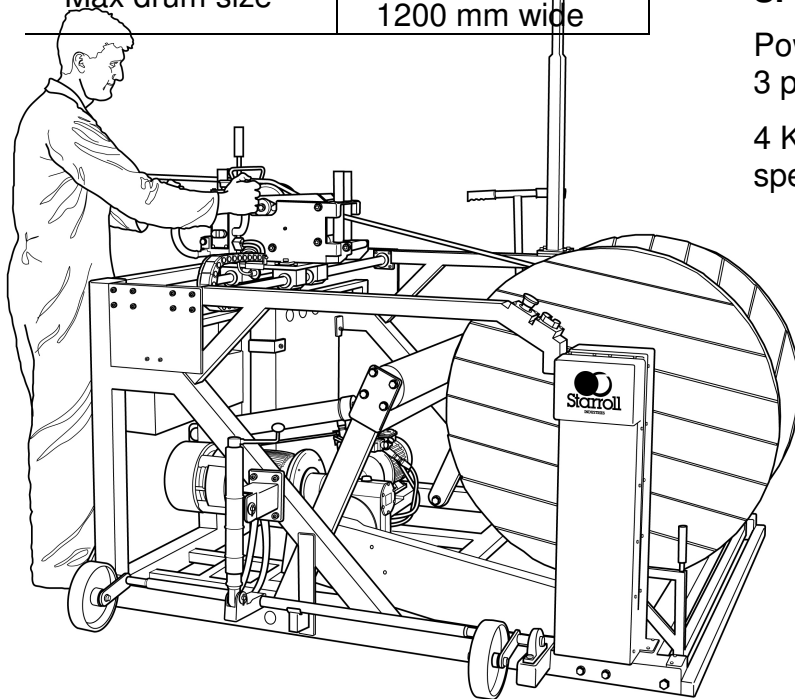

SPECIFICATIONS

Power supply required: 20 amps 415 volts
3 phase and earth.

4 KW A.C. 3 phase brake motor with inverter
speed control.

Programmable metric electronic counter, allows for the winder to be recalibrated. Automatic switch-off of winder at the end of preset cable length.

Electronic encoder on the measure wheel, paired with the electronic counter, gives an accurate measurement of cable.

A speed control pot is fitted to the meter head for better operator control of winding speed.

A slow down speed operates 10 metres from the end of preset cable length (adjustable).

Automatic switch-off of winder at the end of preset cable length.

Weight	500kg
Width	2130mm
Depth	1870mm
Height	1385mm

An electric brake will operate in the event of:

- Loss of mains power.
- Emergency stop button being pressed.
- Inverter is not running.
- Proximity Switch in hand grip is released (dead man switch).

WINDING AND MEASURING EQUIPMENT

Telephone +61 8 8258 1724 • Fax +61 8 8258 9560 • info@starroll.com • www.starroll.com

RDW1

Rim drive winding machine

Small drum and coil winding system

A secondary drive system (axle drive) allows for the winding of loose coils and smaller drums.

A coiling cage is supplied.

Drum inching can be achieved by using the forward or reverse jog buttons – 3 points of control.

A hydraulic ram with an electric/hydraulic pump is fitted to allow for drum size adjustments and ejection.

Mechanical screwjacks assist wheels in lifting and lowering the winder.

Pivot wheel and handle fitted for easy manoeuvring of winder.

Winder designed to run parallel to cable rack systems.

A tool box is fitted for storage of loose tools, tape etc.

ELECTRICAL PROTECTION

Motor start circuit breakers inside control cabinet for main drive and hydraulic pump motors.

Inverter has inbuilt protection.

Three emergency stop buttons for operator protection.

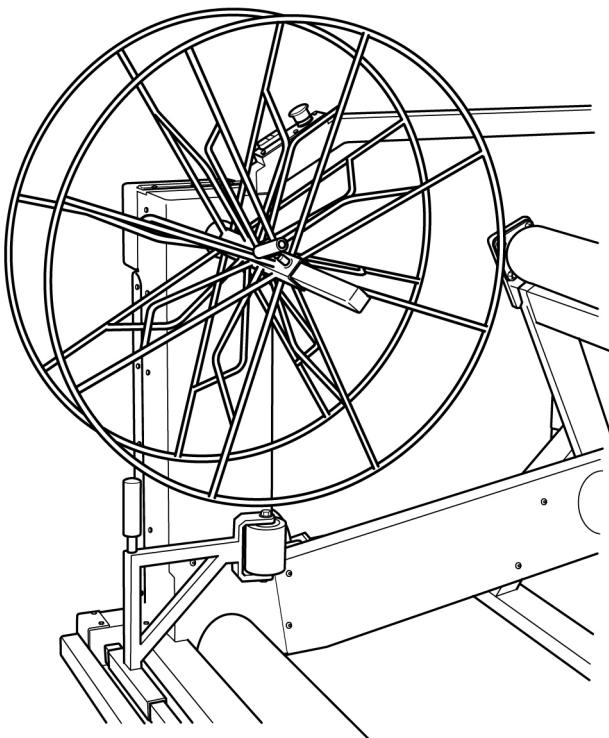

WINDING AND MEASURING EQUIPMENT

Starroll Industries Pty Ltd
Telephone +61 8 8258 1724 • Fax +61 8 8258 9560 • info@starroll.com • www.starroll.com